



DVI Fiber Optic Cable (OLC Series)

This unique DVI fiber optic converters lets your digital display(Plasma Monitors, Digital Projectors, LCD Monitors,) extend up to 2300 ft. (700 meters) away from the video source based on DVI standard. Our patented of optical conversion technology enables noise-free and high res(UXGA) extension upto 2300ft. Ideal for fishing through small openings as the connectors are detachable from the fiber optics cables(requires only 1/2 inch opening)



MAIN FEATURES

- Separate DVI-D converter modules for transmission and reception are connected with four separate multi-mode fiber optic cables terminated in LC connectors.
- These are all integrated into a single cable with wrapped in a PVC jacket.
- Ideal to run small conduits or small openings as the connectors detachable from the cables (requires only 1/2 inch opening).
- Shipping Resolutions: SVGA(800x600), XGA(1024X768), SXGA(1280x1024), UXGA(1,600x 1,200)@60Hz
- EDID parameters factory preprogrammed inside the transmitter housing(If your display supports up to XGA(1024x768), or HDTV resolutions(480p,720p,1080i/p) please call or e-mail after order).
- External 5V power supply adapter included.

APPLICATIONS

- Video Wall System
- Large LED Sign Board
- Medical Imaging Equipment
- Airplane On-board Video System
- Auditorium
- Conference Room Video Equipment
- Church Video System

CONNECTION FEATURES

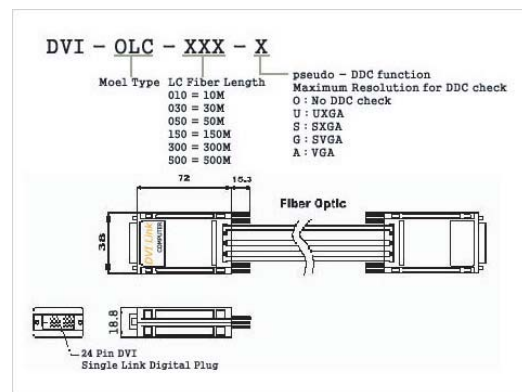
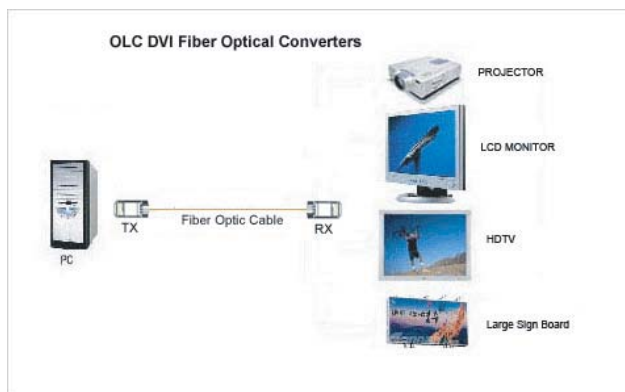

TECHNICAL SPECIFICATIONS

- DVI Bandwidth: 25-165 MHz (DVI-D single link)
- Supports Resolution: Up to UXGA, 1080p
- Shipping Resolution:SVGA(800x600), XGA(1024X768), SXGA(1280x1024), UXGA(1,600x 1,200)@60Hz, Please call for WUXGA or HDTV(480p,720p,1080i/p) resolutions.
- Connector Type:DVI-D male 19pin/ fiber optic cables with 4 simplex LC Connectors
- Maximum Distance:700m(approx.2,300 ft.)
- No EMI characteristics, Meet FCC class A(ICES-003) and CE class A.
- Power Consumption:Transmitter 1.65 Watts(Max.) Receiver 2.48 Watts(Max.)
- Optical source:850nm Vcsel
- Optical Cable Type:50/125 or 62.5/125 LC Multi-mode Fiber
- Power Supply:DC 5V,600mA Adapter Included.
- HDCP non compliant.

2009-05

Ein Vertriebsprodukt von:

VIDELCO – Professionelle Audio-, Video-, Medien-Technik!

Telefon: +49 (0)2102 / 86 39-00 • Fax: +49 (0)2102 / 86 39-17 • info@videlco.eu • www.videlco.eu

