

Floorbox Panel Interface for DVI and Stereo Audio signals designed for 45x45 mm systems

Lightware FPI-DVI-Audio-100 is an active floorbox interface supporting DVI-D and Stereo Audio signals. The Floorbox Panel Interface is designed for European 45 mm x 45 mm module system allowing aesthetic system integration. The DVI repeater equalizes the incoming DVI-D signal and boosts it on the output allowing long distance cable routing from the floorbox to the system rack equipment. FPI-DVI-Audio-100 is compliant with HDCP encrypted DVI and HDMI signals. Stereo Audio signals coming from laptop computers are actively converted to balanced audio format to ensure noise free long reach transmission to professional audio equipment. 3.5 mm Phoenix Combicon connectors with screw termination for Audio and power connection guarantees the reliable system integration and cabling. The unit can be powered from DVI source device (laptop, computer, set top box etc.) through the input DVI connector's pin14, or externally from the remote location. The power source can be set up by jumper located on the interface.



Applications

- Professional AV systems
- Conference rooms, classrooms
- Network Operation Centers
- Medical imaging

Features

- DVI and HDMI repeater
- HDCP compliant
- Cable Equalization on inputs
- Signal boost on output
- Balanced Audio output
- DDC pass through
- Analog RGB pass through

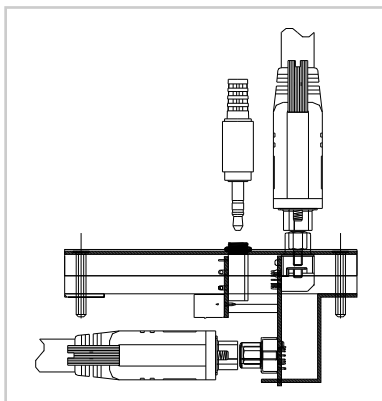

Connectors

Input / Output:	29 pole DVI-I connector
+ 5V Power:	2 pole Phoenix Combicon
Audio input:	3.5mm Jack
Audio output:	3.5mm 5 pole Phoenix Combicon

Specifications

Signal Routing:	DVI 1.0 with HDCP, HDMI1.3
Bit rate:	2.25 Gbit/s per color, 6.75 Gbit/s in total
Input equalization (DVI):	+12 dB
Output Boost (DVI):	+6 dB jumper selectable
Resolution:	from 640x480 to 1920x1200 or 2048x1080 deep colour
HDCP compliant:	Yes
Power:	50 EDID
EDID support:	256 byte Extended EDID
+5V Power on DVI Outputs:	300 mA
Power:	DC 5 Volt, 250mA
Power consumption:	0.9809 W (Typ) 1.2717 W (Max)
Compliance:	CE
Dimensions:	89,5W x 45,5D x 42H mm
Net weight:	75 gramms
Warranty:	3 years